

NOTES:

1. SPECIFICATIONS:

STROKE:	3.25 IN. (82.5 mm)
LENGTH:	11.5 IN. (292 mm)
MAX. LENGTH:	15.0 IN. (381 mm)
HANDLE WIDTH:	8.0 IN. (203 mm)
WEIGHT:	4.4 LB. (2.0 kg)
MAX APPLIED STRAP TENSION:	2500 LB. (1134 kg)
MAX HANDLE FORCE:	46 LB. (20.9 kg)
COLOR:	BLUE

2. PANDUIT BT75SDT USES:

INSTALL 0.75" (19.1MM) WIDTH STRAPPING ONLY.

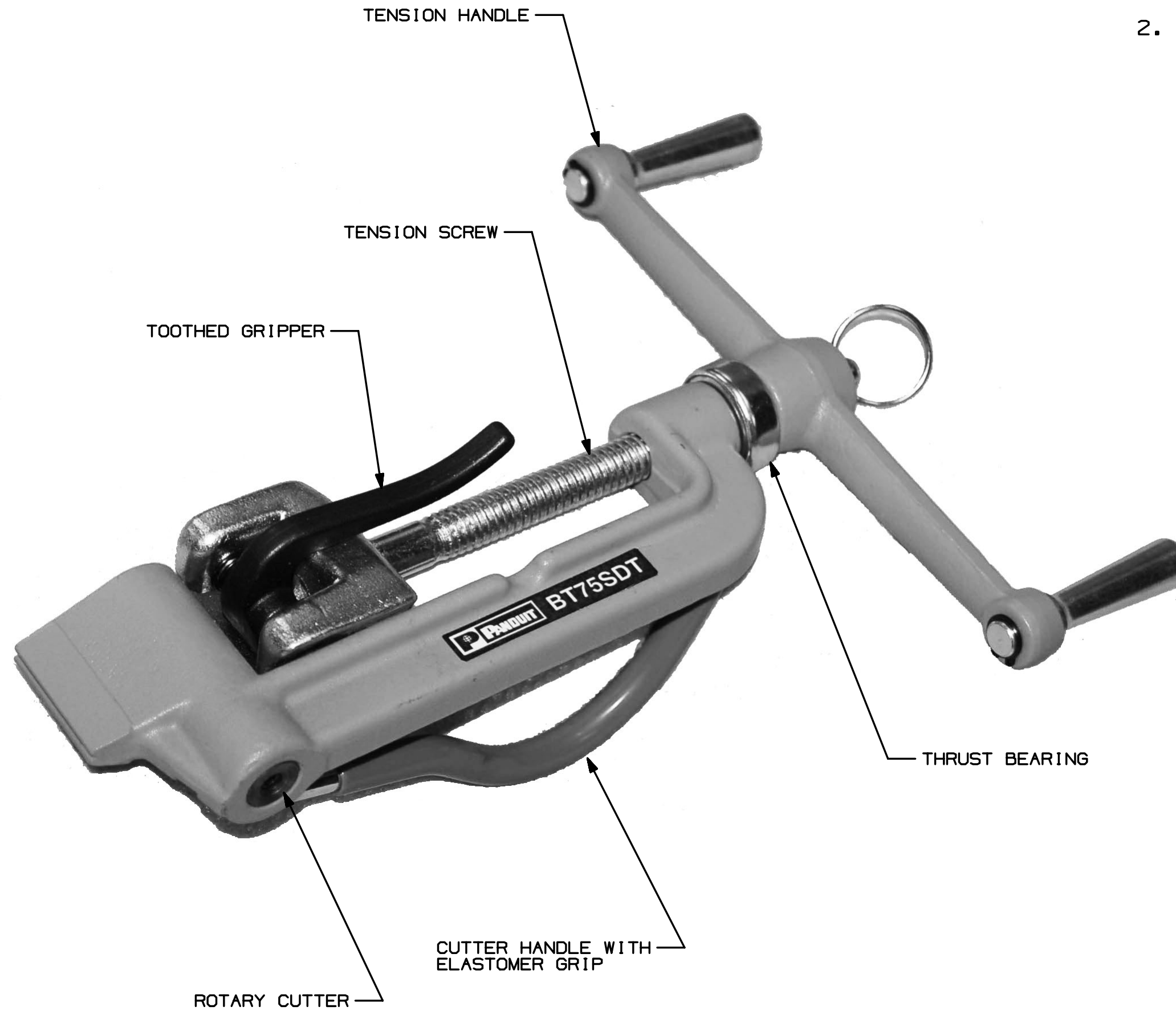

										CAD FILENAME/LAYERS		R26069BA_TM26069C01/01A		
										PANDUIT CORP TINLEY PARK, ILLINOIS BT75SDT * CUSTOMER DRAWING				
										UNLESS OTHERWISE SPECIFIED, DIMENSIONAL TOLERANCES ARE: (.X) ± .010 (.XXX) ± .005 (.XX) ± .005 ANGLES ± .010		UNLESS OTHERWISE SPECIFIED, ALL DIMENSIONS ARE GIVEN IN INCHES, THIRD ANGLE PROJECTION		
01	8-5-13	JEH	ASJ	UPDATED NOTES	4812	--	ASJ	DRAWN BY	PWG	MAT'L:	SCALE		NONE	
00	04-30-09	PWG	ABJ	RELEASED	4377	--	ABJ	DATE	04-30-09	-----	DRAWING NO.	TM26069C01	DWG SIZE	C
REV	DATE	BY	CHK	DESCRIPTION	ECN	R	CUST	SUP	CHK'D	ABJ				